

MAIN APPLICATION	TYPE	MAGNET	
		Telecom	50mm

GASKET	MEMBRANE	BASKET	WEIGHT	REMARKS
-	Plastic	PP + GF	47 ±5g	Horizontal Tags

ITEM	SPECIFICATIONS	VALUES	TEST CONDITIONS
1	Dimensions	∅50mm	per mechanical Drawings
2	Impedance	50Ω ±15%	1kHz / 1.0V
3	Nominal Power	0.3 Watts	
4	Max Power	0.8 Watts	
5	Resonant Frequency	390Hz ±15%	1.0V
6	Sensitivity (S.P.L.)	77dB ±2dB	0.1W/1m, Average 0.6/1.0/2.0/3kHz
7	Frequency Response	390Hz to 4KHz	0.1W/1m; Tolerance Max 15dB
8	THD	2% max	1kHz 0.1W/0.1m
9	Storage Temperature	-25°C to +80°C guaranteed range for transportation & storage	
10	Polarity	Membrane move forward when positive DC is applied to the '+' terminal	

PACKAGING	SPECIFICATIONS	
Carton size:	365x365x160mm	
Qty/Carton:	216 (6 layers of 36pcs)	
Gross Weight:	12.5Kg	

Mechanical Drawings (in mm)

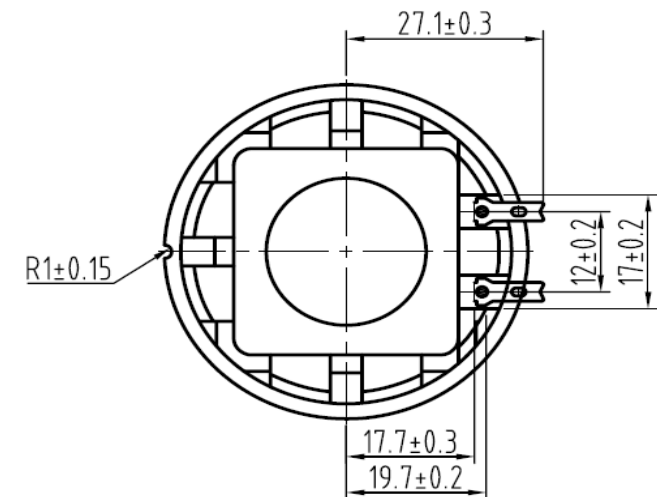
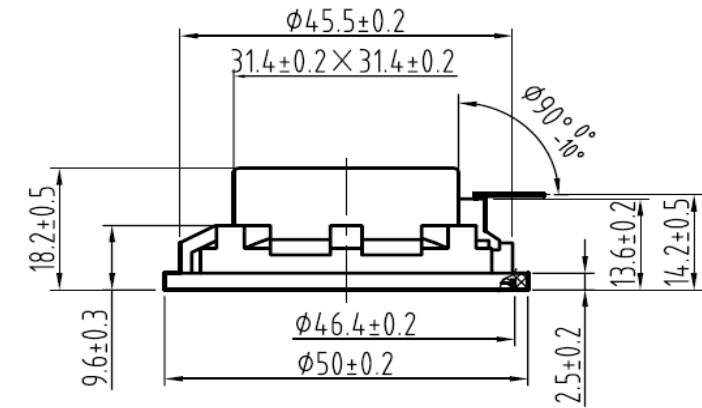

ITEM	TEST	TEST CONDITIONS	RESULT
11	Rub & Buzz	Rated Power Sin wave (speaker frequency range)	No Buzzes or Rattles.
12	High Voltage Resistance	100VAC / 1mn between terminals and frame.	Must be normal
13	Insulation Resistance	100VDC between terminals and frame.	≥ 1MΩ
14	Load	White Noise at Rated Power for 96h	After 1 hour of rest at room ambient conditions, speakers must meet specs items 2, 5, 6.
15	High Temp.	+60±3°C for 96h (random 20%-50%RH)	
16	Low Temp.	-25±3°C for 96h (random 20%-50%RH)	
17	Humidity	+40±3°C ambient and 90%RH for 96h	

Typical Frequency Response

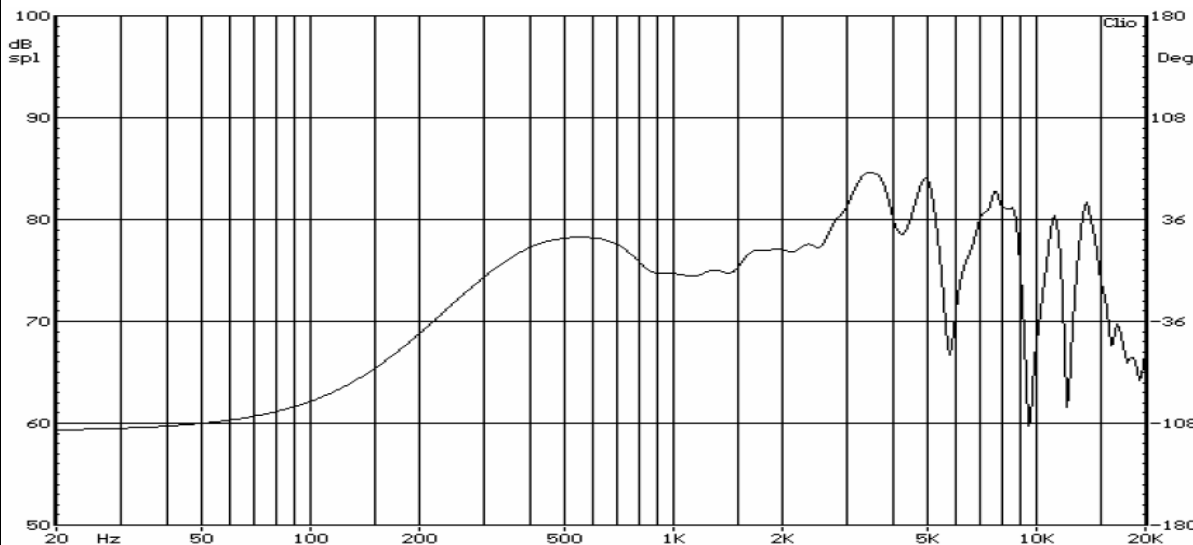

Measured on axis at a distance of 1m with 0.1W input power

Part n°			
SOD20722Y50LH			
REV	DATE	SHEET	
0;1	01/08/2017	1 of 1	RoHS Compliant